

**RoHS**  
Compliant

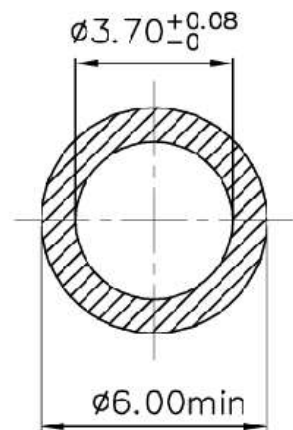
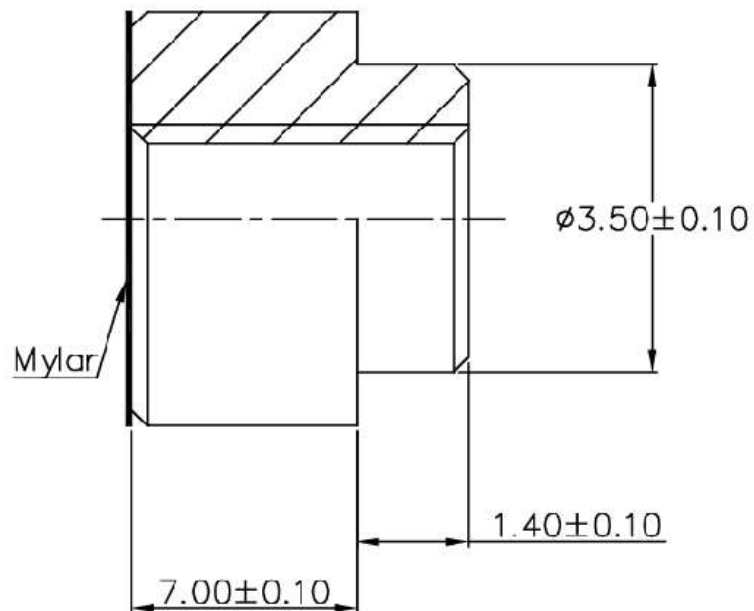
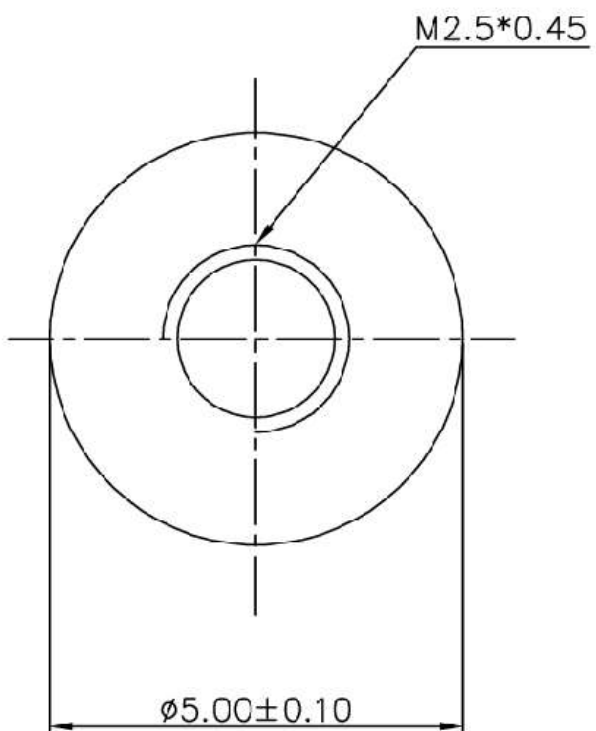

Stencil Marking Examples

REVISION RECORD				SCOPE		Plastech	
DATE:	NEW REVISION	REVISION PERSON	REVISION DETAILED	X.	$\pm 0.20$	X'	$\pm 4'$
/	/	/	/	.X	$\pm 0.10$	.X'	$\pm 2'$
				.XX	$\pm 0.05$	.XX'	$\pm 1'$
			Package Type:	Steel 1215		Unit: mm	Custom Confirm:
			Reel package	Finish: Tin		Material:	APPD: Alan Wu
			Quantity: 600pcs/Reel			DRAMN: Yong Wu	DATE: 2018/06/08
						DATE: 2018/06/08	DATE: 2018/06/08
						BASED ON:	PART NUMBER: SMT2570
						STANDARD REFER: CUSTOM DWG	DESCRIPTION: M2.5*5*7+1.4
						SCALE: /	PART NUMBER: /
						SHEET :1 OF 1	DESCRIPTION: /
							REVISION: A
							REVISION: A